

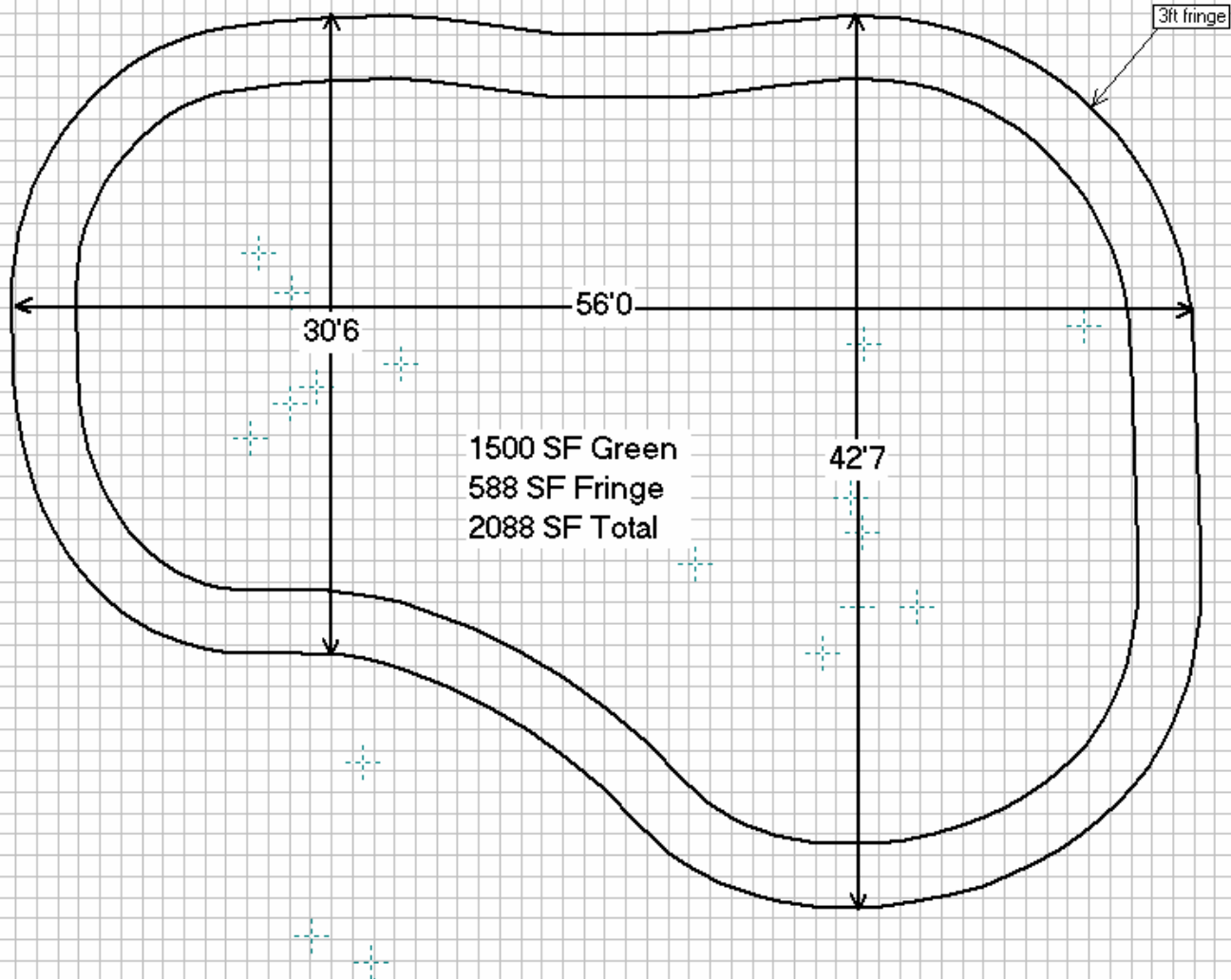

## **STEPS TO CALCULATING, PREPARING AND CUTTING FRINGE (BASED ON A 15' ROLL)**

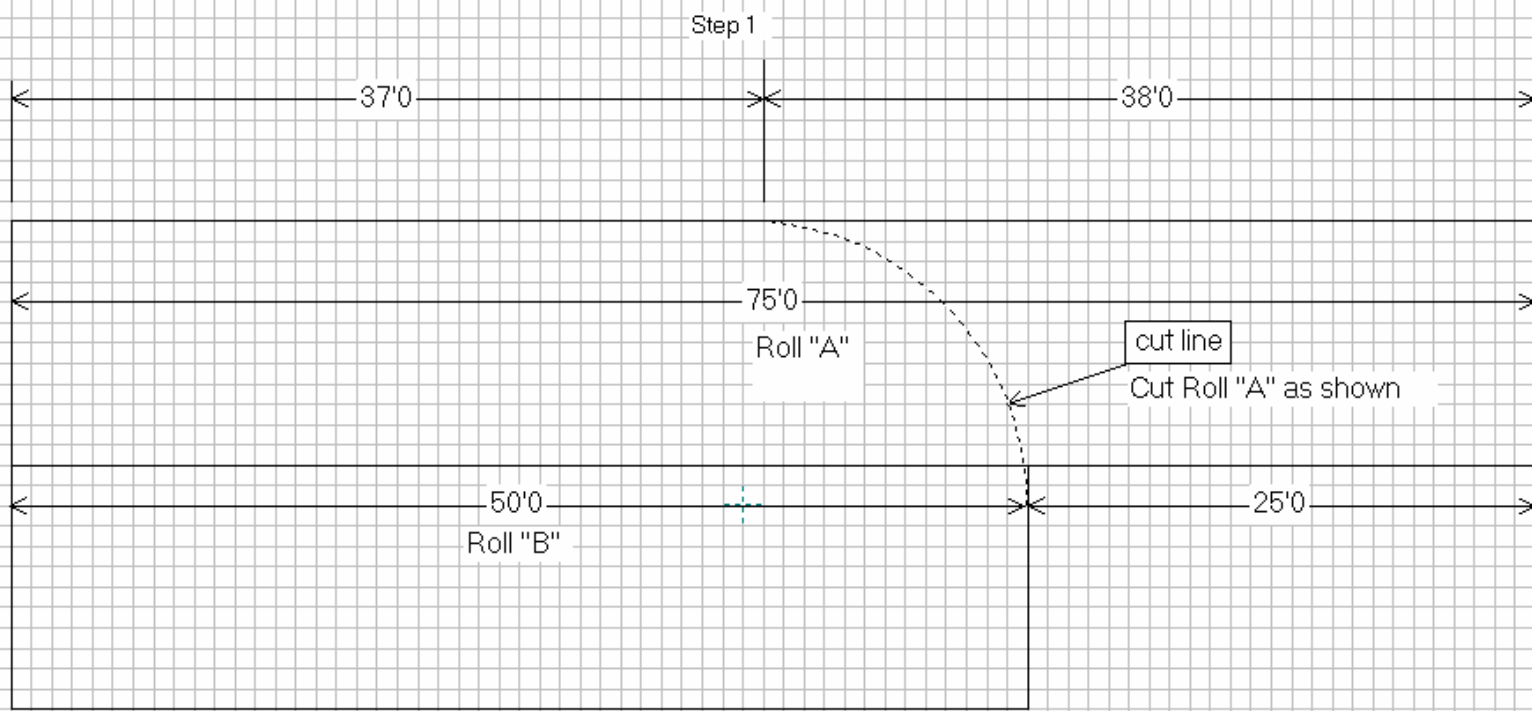



Start with 2 Rolls  
roll "A" 75' long  
roll "B" 50' long

Step 2

